

Ask for Your Demonstration

RefinIR™

The New Refinery Products Analyzer

- Mid-Range FT-IR
- Heavy Petroleum Analysis
- Swipe and Go Simplicity
- Multiple refinery parameters with one sample
- Pre-qualify new feeds, blends, and/or mid-stream components



Portable FT-IR Spectrometer

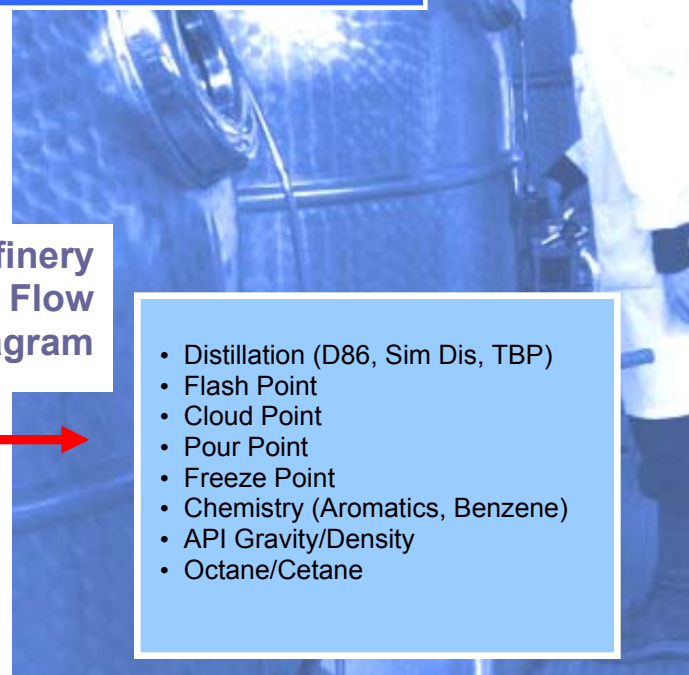

Refinery Process Flow Diagram

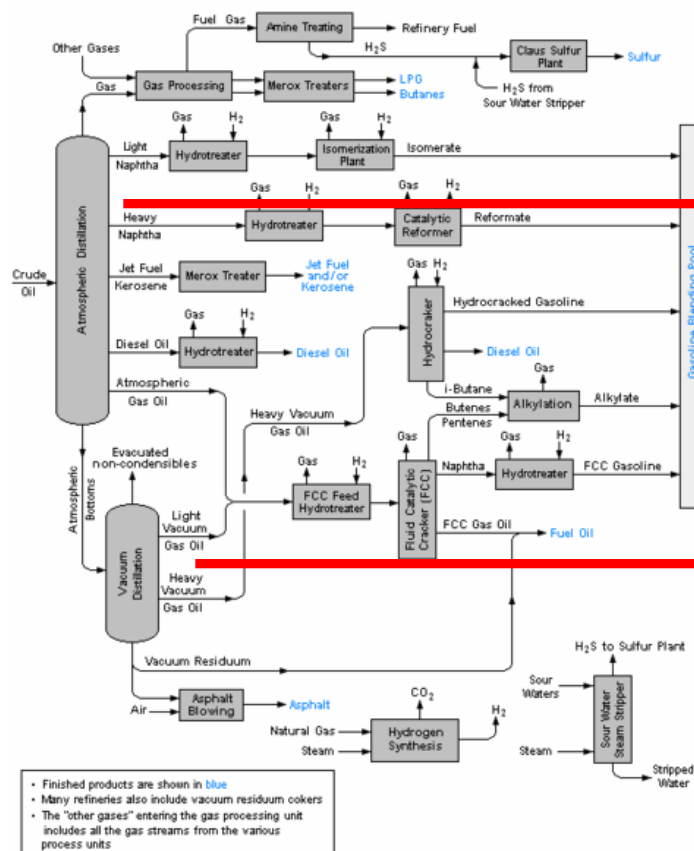

- Distillation (D86, Sim Dis, TBP)
- Flash Point
- Cloud Point
- Pour Point
- Freeze Point
- Chemistry (Aromatics, Benzene)
- API Gravity/Density
- Octane/Cetane

- FCC
- Feed Density
- Carbon Residue
- Vacuum Gas Oil Density
- Hydrogen Content
- Total Carbon Aromaticity
- MCRT
- Mono-aromatics
- Di-aromatics